

2010-12

# An evaluation of public aids towards renewable energy sources in Spain

Ferreira, José Luis

---

<http://hdl.handle.net/10016/9796>

---

*Descargado de e-Archivo, repositorio institucional de la Universidad Carlos III de Madrid*



Working Paper 10-37  
Economic Series  
December, 2010

Departamento de Economía  
Universidad Carlos III de Madrid  
Calle Madrid, 126  
28903 Getafe (Spain)  
Fax (34) 916249875

## **An evaluation of public aids towards renewable energy sources in Spain<sup>1</sup>**

José Luis Ferreira<sup>2</sup> and Álvaro Escribano

Department of Economics

Universidad Carlos III de Madrid

### **Abstract**

Public aids towards renewable energy sources in Spain have had the consequence of a great increase in their use. This is particularly true for the case of wind generation. For the year 2007, we show that the savings in social costs due to carbon emissions account for a figure between 25% and 78% of total aids. Since some of the public aids are just a money transfer with no effect on total social welfare the justification of the net costs of the aids is higher. For the particular case of wind generation, we find that in the worst case scenario 45% of the social cost implied by the public aids is justified by the reduction in carbon emissions, and that the benefits of CO<sub>2</sub> reductions are 135% higher than the costs in the best case scenario.

---

<sup>1</sup> The authors gratefully acknowledge financial aid by IDAE.

<sup>2</sup> Corresponding author: Department of Economics, Universidad Carlos III de Madrid, C/ Madrid, 126 Getafe, Spain. Tel: 34 916249580, e-mail jlferr@eco.uc3m.es.

## 1. Introduction

Public aids towards a given economic activity must be justified as welfare enhancing, typically as a correction of a market failure. In the case of electricity production, a negative externality is associated with CO<sub>2</sub> emissions and pollution. These externalities call for a mechanism in which firms internalize the costs of emissions. However, such a mechanism failed to exist in the last decade in Spain.

In its absence, a mechanism to promote the use of clean, renewable energy sources, RES, has been put in place instead. Under this mechanism, energy sources listed in the Special Regime have public aids, typically in the form of feed-in-tariffs. In the Spanish system the dairy price for electricity production is determined in a market mechanism, and all energy sources are rewarded the same market price. This means that RES are assigned the market price plus a premium.

We compute the change in total welfare due to this policy considering the private and total costs of the different technologies. In the computation of the total costs we add to the private costs only the estimated social costs of CO<sub>2</sub> emissions. This is a low estimation of the change in welfare, as there are other negative externalities of non RES like pollution, and there may be other positive aspects in the use of RES, like the decrease of energy dependence, and the advantage of being first in developing the RES technology and of acquiring the necessary expertise to use it in a sizeable market.

We find that, for the year 2007, the savings in the social cost of CO<sub>2</sub> emissions public represent a figure between 25.6% and 78.1% of the aids toward RES, depending on the scenario. Wind, biomass and mini hydro show numbers around this average, while solar power show much lower figures.

Further, for the case of wind generation, we find that only 2/3 of the public aids were necessary to make wind production profitable. This means that 2/3 of the aids correspond to the difference in costs between wind and the best available alternative, while 1/3 is a money transfer from consumers to producers. When we subtract the last part from our calculations, we find that the increase in welfare because of fewer CO<sub>2</sub> emissions constitute a percentage between 43.9 and 135.0 of the net cost of the aids to wind generation. This is particularly important as wind is by far the most important renewable energy source that receives public aids.

The difference between these percentages and 100, if any, must be justified by other benefits for the policies to make economic sense.

We think that these numbers provide a nice perspective on this particular economic policy, and that in particular show how, in the worst case scenario (the other benefits are small) the cost-benefit analysis is not unfavourable to it except in the case of solar energy.

We have chosen the year 2007 for several reasons. The most important is that it is the most recent year without any atypical feature. Up to that year, there was practically no other incentive to use RES than the public aids, as the market for emissions was either inexistent or inefficient. Also, the most reliable data on costs come from reports made early in the year 2008, presumably using data from the year before.

Section 2 provides the private costs for electricity production. Section 4 considers the social costs of emissions. Section 4 shows the electricity production in Spain in 2007. Section 5 presents the cost-benefit analysis. Finally, Section 6 concludes.

## 2 Private costs

The private costs of electricity production for all technologies are not easy to estimate. We have some data offered by CNE<sup>3</sup> (2008a), OMEL<sup>4</sup>, Soliño and Prada (2008) and El Mundo (2008). The data reported by CNE and OMEL include the price of CO<sub>2</sub> in the European market for emissions, that in the month for which the costs were estimated reached an average price of 18 euros a metric ton. The data in OMEL shows the offers in the daily market that serves to estimate the curve of marginal costs for non-basic technologies<sup>5</sup>. Based on those reports, Table 1 offers an estimation of the costs by technology excluding the emissions' rights for CO<sub>2</sub>.

The data in Table 1 will be useful to later compare the costs with the public aid towards the renewable energy sources, RES, and also with the price for carbon emissions. As we will see later, the exact cost will not matter in the computations of the savings in CO<sub>2</sub> emissions costs in Section 5 due to public aid towards RES. The exact costs for some of the technologies, however, will be important in determining the change in the social surplus associated with the aid.

**Table 1**  
**Private cost of electricity generation in Spain 2008 excluding emissions**

	c€/ kWh
Hydro	4,3
Nuclear	4,0
Coal	5,2
Fuel	9,05
Gas	6,0
Wind	8,4
Solar	43,0

Source: Own elaboration <sup>6</sup> using data in CNE (2008a), OMEL, Soliño and Prada (2008), and El Mundo (2008).

## 3. Environmental costs

There are different types of externalities produced by emissions. On the one hand we have pollution (basically in the atmosphere) and, on the other hand, emissions that affect the climate change. In spite of certain regulations in the use of the different technologies, we are still far from the internalization of all social costs by the producer. The European Commission (2003) presented a study detailing the external costs of electricity generation. Table 2 presents these costs for Spain. The minimum costs

<sup>3</sup> CNE, Comisión Nacional de la Energía is the regulatory agency for the energy sector in Spain.

<sup>4</sup> OMEL, the Spanish market operator for electricity offers data on the daily market in <http://www.omel.es/frames/es/index.jsp>. We take the data as reported in Sáenz de Miera *et al.*, (2008).

<sup>5</sup> The basic technologies, nuclear, wind and solar offer their production at cost zero.

<sup>6</sup> See Appendix for details.

considers a cost of 18 euros a metric ton for CO<sub>2</sub>, whereas the maximum considers a cost of €46.

IDAE (1999)<sup>7</sup> studies more extensively all external costs in each technology. In the first phase, already completed, each technology is assigned a number of *ecopoints* according to their environmental impact (more *ecopoints* mean a higher impact). The second phase will evaluate the economic impact of the *ecopoints*. This phase is not done yet and thus we cannot use it to quantify the costs, but we can observe that, for most of the technologies, the effects on climate change (basically, the impact of CO<sub>2</sub> emissions) is only a fraction of the total externalities on the environment and health. According to this report, the estimations by the EC (2003) report of the costs excluding CO<sub>2</sub> are greatly infra estimated.

**Table 2**  
**The externalities of energy in the CE 2003 report**

External marginal costs in 2003 c€/kWh	Marginal cost of environmental impact (excluding CO <sub>2</sub> )	Marginal cost of all environmental impacts (including CO <sub>2</sub> evaluated at €18 /Tm)	Marginal cost of all environmental impacts (including CO <sub>2</sub> evaluated at €46 /Tm))
Coal	3.07	5	8
Fuel	2.07	4	7
Gas	0,36	1	2
Wind	0,2	0,2	0,2
Biomass and biowaste	3	3	3
Cogeneration (heat and electricity)	0,13	0,33	0,66
Solar	0,6	0,6	0,6

Source: Own elaboration<sup>8</sup> based on data in the EC (2003) report.

### 3.1 CO<sub>2</sub> emissions

The environmental impact of the different technologies has induced different types of public policy in Spain. In the case of nuclear power, there is a political decision to put a halt in the construction of new plants. Also there is a tacit political decision not to give licenses to open new coal plants. The most recent decisions in energy policy are the public aids towards renewable energy (and other clean technologies) and the creation of an European market for CO<sub>2</sub> emissions.

In this work we do not question the political and scientific reasons regarding the negative consequences in climate change of CO<sub>2</sub> emissions. Our job is to provide a perspective on the magnitude of the estimation of those emissions costs and the increase

<sup>7</sup> Institute for the Diversification and Savings in Energy. This study is conducted by a group of experts from AUMA and by professors from the universities of Barcelona, Polit cnica de Catalu a and Rovira i Virgili, and has been promoted by APPA, with the participation of seven public institutions in Spain (among them, IDAE). It can be found in: [http://www.appa.es/descargas/Resumen\\_Estudio\\_ACV.pdf](http://www.appa.es/descargas/Resumen_Estudio_ACV.pdf)

<sup>8</sup> See Appendix for details.

in production costs due to the use of low carbon technologies, and also provide an estimate on the efficiency of the public incentives to reach the goal of reduction in emissions costs.

There are different estimations for CO<sub>2</sub> emissions for a given technology, among them, the SGE<sup>9</sup> (2009), REE<sup>10</sup> (2009) and WEC (2007). The last two include the complete life cycle of the generation plant (including construction and installation.) We also use consider the levels for CO<sub>2</sub> emissions implicit in Table 2, according to the EC (2003) report. Table 3 shows the average of the data in those different sources and constitutes the basis, along with Table 1, for the elaboration of Figure 1.

**Table 3**  
**CO<sub>2</sub> emissions in electricity production (life cycle)**

	grams/kWh	Increase in cost for every €10/Tm in the price of CO <sub>2</sub> (c€/kWh)	Cost in emissions rights at €25/Tm of CO <sub>2</sub> (c€/kWh)
Hydraulic	4	0.004	0.01
Nuclear	6	0.006	0.015
Coal	950	0.95	2.375
Fuel	754	0.754	1.885
Gas	430	0.43	1.075
Cogeneración (heat and electricity)	300	0.3	0.75
Wind	3-22	0.003-0.022	0,031*
Solar	60-150	0.06-0.15	0,262*
Biomass	Neutral	0	0

\* range average

Source: Own elaboration<sup>11</sup> using data from SGE (2009), REE (2009), WEC (2007) and EC (2003)

### 3.2 The market for emissions

The European market of emissions was created in 2005<sup>12</sup>. The price for a Tm of CO<sub>2</sub> starts around €9, after dropping a few weeks to less than €7, it rises to almost €30 that summer. After some ups and downs it finally drops and reaches the price of 1€ in January of 2007 and of €0.13 in June. According to all analysts this was due to the fact that too many emissions rights were given. In fact, and anticipating a cut in the second phase, the market price for emissions next year was €20 when the spot market price in the current year was almost zero<sup>13</sup>.

<sup>9</sup> The Secretaría General de la Energía is the Office for Energy of the Spanish Ministry of Industry.

<sup>10</sup> REE (Red Eléctrica de España) is the Spanish system operator for electricity. The estimation can be seen in its web page:

[http://www.ree.es/sala\\_prensa/web/inc/fichero.aspx?ruta=notas/documentos&fichero=hn85h1pid679.pdf](http://www.ree.es/sala_prensa/web/inc/fichero.aspx?ruta=notas/documentos&fichero=hn85h1pid679.pdf)

<sup>11</sup> See Appendix for details.

<sup>12</sup> Jensen and Skytte (2003), Morthorst (2001) and Morthorst (2003) show the state of the question in the years previous to the implantation of the market for emissions.

<sup>13</sup> Data on CO<sub>2</sub> prices in the European market for emissions can be found in European Climate Exchange: <http://www.ecx.eu/>

In effect, the second phase (2008-2012) was more ambitious. The number of emissions rights was reduced a 7% with respect to 2005. During the summer of 2008 it reached €30 and, because of the crisis, in January of 2009 it dropped below €10. Figure 1 shows the evolution in prices (as negotiated in the current year and the in years before.)

**Figure 1**  
**Evolution of CO2 price**

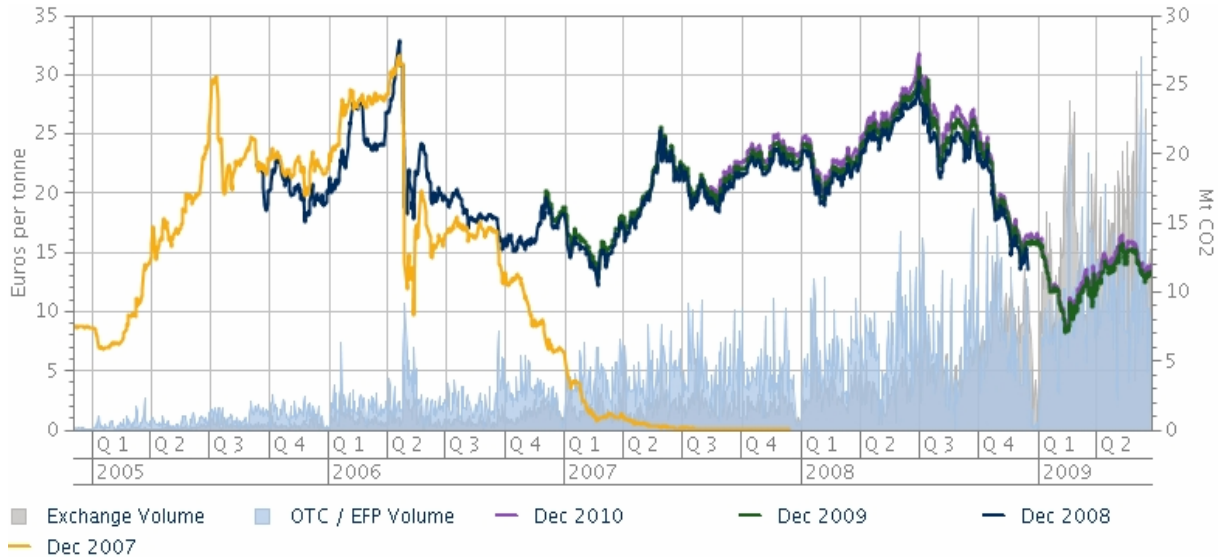

Source: European Climate Exchange

The inexistence of a market before 2005, its volatility in the 2005-06 period, and the virtual zero price in 2007 indicate that the market for emissions was not the adequate mechanism to correct the externalities due to CO2 emissions. A cost-benefit analysis should compare the public aid towards RES and its effect on reduction of emissions beyond what the price of CO2 implied in decisions by firms.

#### 4. The electricity production in Spain in 2007

Figure 2 shows, for the year 2007, the demand and the quantities produced by each technology. Solid lines show private costs without emissions costs or public aids. Dashed lines for coal, gas and fuel show total costs (both private and public) at a hypothetical emissions cost of 25 euros a metric ton<sup>14</sup>. Dashed line for wind generation

<sup>14</sup> Recall that the average price for carbon emissions dropped to almost zero in 2007. The price for 2008 rights were negotiated at about 25 euros a metric ton at the end of the year 2007.

In European Climate Exchange it has been estimated that €25 is the minimum price for the incentives to switch to clean energy to work in a way that allows to reach the international goals. More recently, in Allianz Knowledge (2010) Patrick Birley, the Chief Executive of European Climate Exchange is quoted saying that the “price really drives behavior at around 35 Euros a ton of CO2”.

Carbonpositive (2010) estimates the range €20-€60 per ton of CO2 for the year 2020. The same source estimates that, in order to reduce CO2 emissions at the current price for coal, it is necessary that the price in the market for emissions reach €30.

European Commission (2006) forecasts a price for CO2 rights to reach €20 in 2010, €27,5 in 2015, €34,2 in 2020 and almost €40 in 2025.

Point Carbon (2008) shows the result of different opinion pools conducted among participants in the markets for emissions, For 2020 the average answer given in 2008 was €35, with a high percentage of answers close or above €50.

reflects the private cost after discounting the public aid (in the form of feed-in-tariffs). The total does not coincide with the total demand as we do not include solar, biomass and cogeneration of heat and electricity. This is because quantities are smaller and show a variety of costs.

Figure 2 provides just information on quantities and an estimation of costs in the Spanish electricity market and cannot be interpreted as supply and demand curves. In the Spanish system there are 24 markets for every day of the year (one per hour). In any of these markets there will be a different technology mix, depending on the forecasted demand, availability of every technology, and other technical factors.

Nevertheless, the following features of the Spanish system can be observed:

- The aids towards wind generation are more than enough to guarantee private profits, even if CO<sub>2</sub> emissions' rights are free.
- At €25 in the CO<sub>2</sub> price, gas replaces coal (the minimum price for this to happen is around €15).
- Without a market for emissions, the equivalent premium to make wind more profitable than gas must be at a minimum of 2.4 c€/kWh. To make wind more profitable than coal, the minimum must be around 3.2 c€/kWh.
- At €25 in the CO<sub>2</sub> price there is a wide margin to reduce the aids to wind production and still make it profitable: an equivalent premium around 1.4 c€/kWh should suffice.
- A CO<sub>2</sub> price over €30 is necessary for the wind, without aids, to be cheaper than coal (this agrees with the independent calculations in Carbonpositive)
- A much higher price, around €6, is necessary for the wind without public aids to be more profitable than gas.
- The obsolete fuel plants are also the most expensive.

In general, daily offers follow the coal, gas and fuel costs curve (in that order) if the CO<sub>2</sub> price is too low, and follows the order of gas, coal and fuel if it is high enough. Nuclear and wind are the first technologies to enter the system as they are typically offered at zero price to make sure that they will enter no matter what. This is due to the impossibility to start and stop a nuclear reactor at will, and to the zero marginal cost of wind power. Under the Spanish system all technologies receive the same market price.



**Figure 2**  
**Production and costs in electricity generation in 2007**  
**(if CO<sub>2</sub> social cost is 25 euros a ton)**

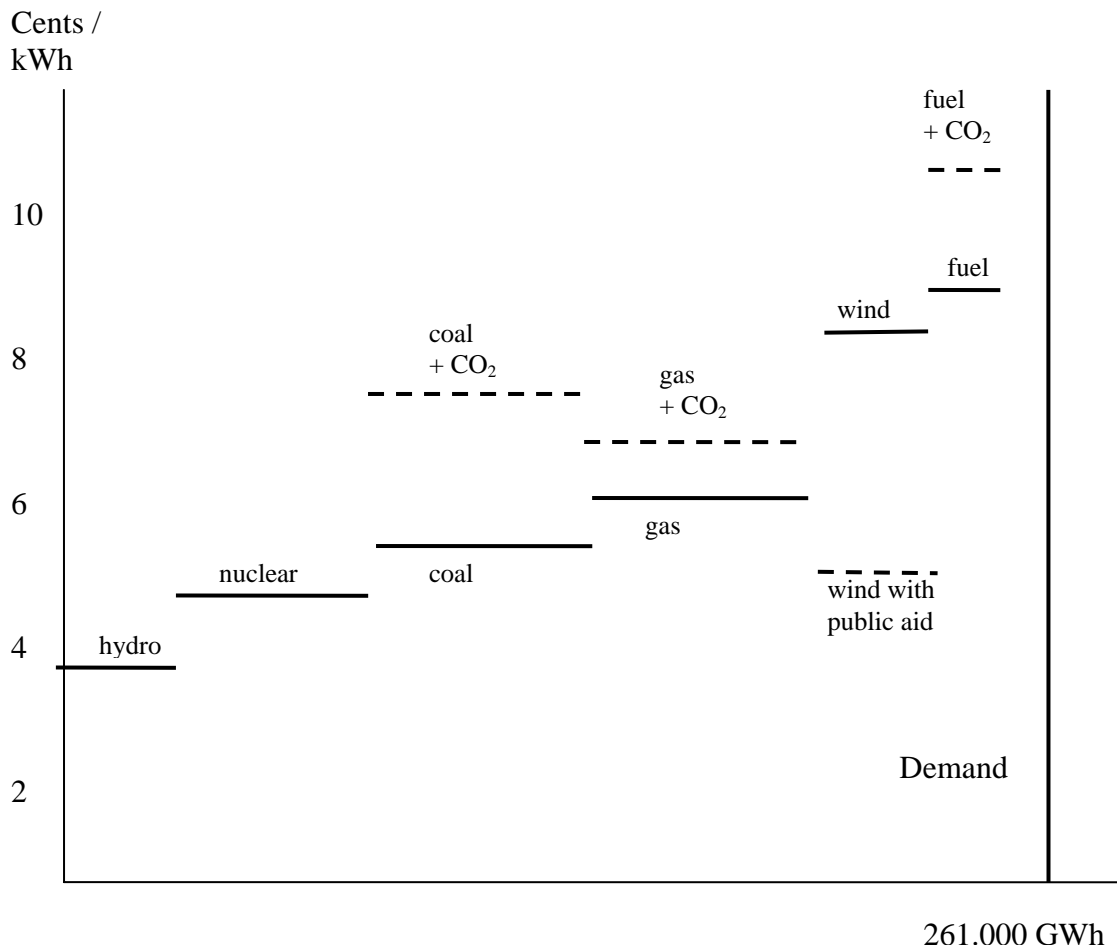

Source: Own elaboration

## 5. The economic impact of the aid towards RES

### 5.1 The welfare analysis of feed-in-tariffs

In this Section we show how to perform a welfare analysis in the Spanish market. Figure 3 shows an example of a market with four technologies, A, B, C y D. In an ideal situation with perfect competition, each firm offers all its capacity at its marginal cost. In this example, given the demand, the market operator accepts the offers by Technologies A and B, and accepts only a portion of technology C. All accepted offers are paid the market price, which is set equal to 4 in the example.

**Figure 3**  
**A market for electricity**

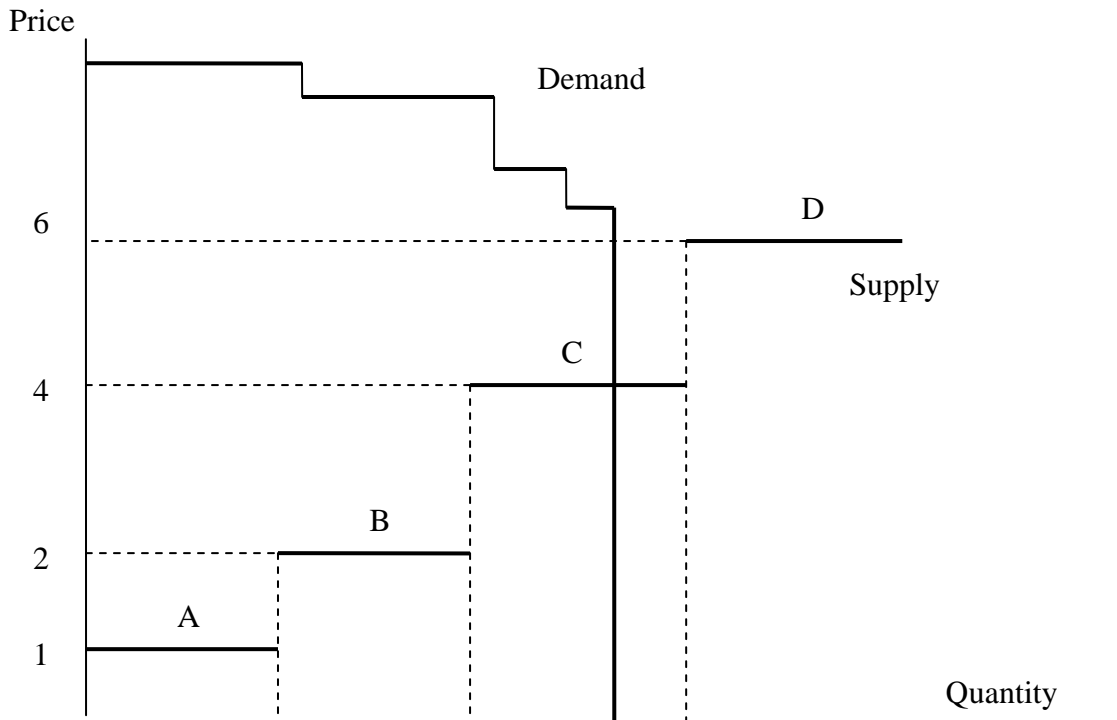

A premium of 3 c€/kWh on technology D changes the order of entry. Figure 4 shows that D enters instead of C, and that the new equilibrium price is 3. The reduction in price from 4 to 3 means an increase in the consumers' surplus of the size of area X + Y (4-3 multiplied by the total demanded quantity).

**Figure 4**  
**A Premium on Technology D**

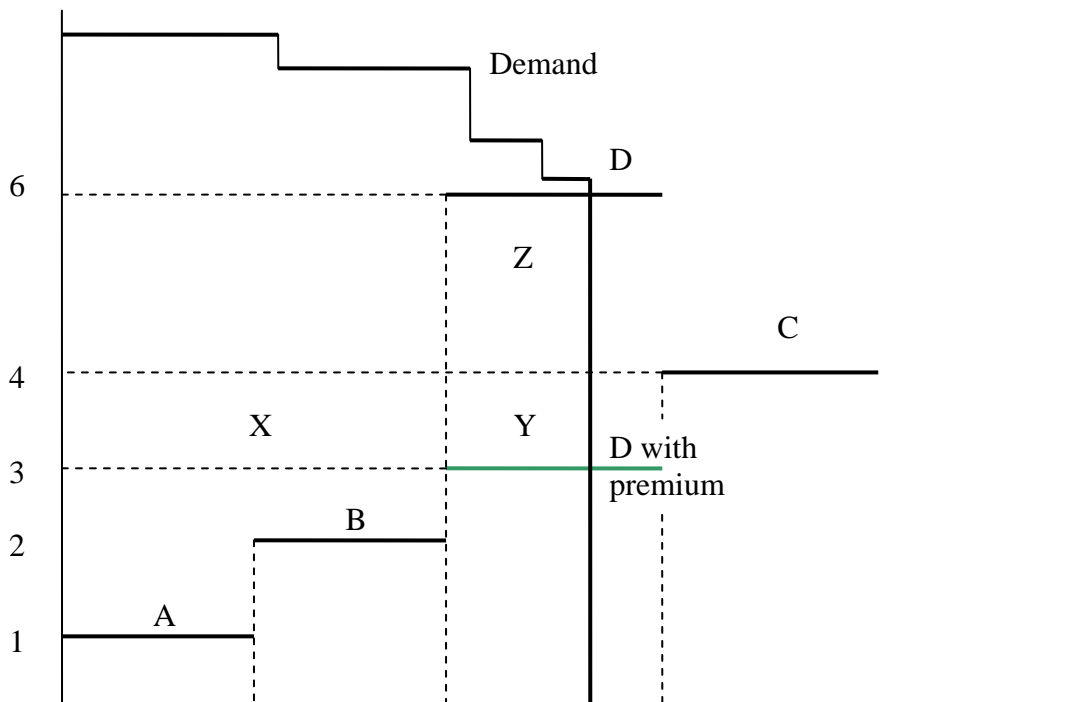

Out of this area, X is an increase in the consumers' surplus, but also a reduction in the producers' surplus. Only area Y is a net gain in the total surplus.

However, this is not the end of the story. Someone has to pay the higher cost of the new energy. In the Spanish case, the electricity bill includes the aid to technology D, which is given by area Y+Z, the premium multiplied by the quantity. Area Y is cancelled by the increase of total surplus due to the reduction in price. Area Z is the net loss of total surplus due to the premium. This area must be compared with the positive effects on externalities due to the switch of technologies C and D, which is the goal of the next section.

Sáenz de Miera *et al.* (2008) compute the effects on consumers' surplus (X+Y) for the aids towards wind generation, and find a net increase (a saving) of 942 millions of euros in 2005, 306 millions in 2006, and 898 millions between January and May in 2007. The possibility of this effect was anticipated in Rathmann (2007). Similar arguments are made in some reports that stress the effect on consumers of the aids towards RES, like AEE (2008b). However, we must insist that these are not net savings.

## **5.2 Reduction in environmental costs and equivalent premium.**

In 2007, the production of renewable energies within the Special Regime (*Régimen Especial*, the ones that receive public aids) represented a total of 40,381 GWh, as shown in Table 4.

Assuming that, in the absence of public aids, none of the 40,381 GWh would have been produced by the renewable sources of energy, another technology should have taken over this part of the demand. Given the physical impossibility of more hydroelectric plants and the political restrictions to build more nuclear plants, in the best of the scenarios (from the point of view of fewer emissions), the production would have taken place with the use of gas plants. A gas plant emits about 430 grams of CO<sub>2</sub> per kWh (see Table 3). To calculate the difference in emissions, one needs to subtract from that figure the emissions by the RES. As seen in the Appendix, the use of RES meant that, in the year 2007, the sector's emissions were 19 millions of Tons of CO<sub>2</sub> less if the alternative was, indeed, generation with gas. The savings in social environmental costs (CO<sub>2</sub> and pollution) is estimated between 506 and 929 millions of euros, depending on the social cost of CO<sub>2</sub> emissions. The two numbers correspond to costs of 25 and 50 €/Tm, respectively.

To be sure, the savings would have been higher if not all the substitution would have been done with gas. To the extent that the investments in renewable energies have been decided because they were more profitable than gas plants, one can say that gas plants were less profitable than the RES, and that a smaller investment would have taken place in this technology compared to the investment done in RES. This, in turn, implies that there was some use for the existing coal and fuel plants.

**Table 4**  
**Production with Renewable Energies Sources**

2007	Production GWh	Total Revenues (including public aid) (millions €)	Total Public Aids (millions €)	Equivalent Premium (public aid per kWh) (cents €)
Wind	27,474	2,147	995	3.62
Solar	495	215	194	39.19
Hydro	4,120	318	146	3.54
Biomass and Biowaste	8,292	694	329	3.97
<b>Total</b>	<b>40,381</b>	<b>3,374</b>	<b>1,664</b>	

Source: CNE (2008b)

For 2007, AEE (2008a) estimates a reduction in emissions of 17.9 millions of tons due only to the use of wind power. If we follow their methodology, the total for all the RES is about twice as much. Their analysis is based on a simulation of the daily market without wind power, which gives a substitution mix of 55.5% of gas, 38.8% of coal and 5.7% of fuel. If the analysis is extended to the rest of renewable energies, the reduction would have been 32.5 millions of tons. Their estimation takes the production structure as given, and does not consider a more gas intensive sector if more gas plants were built relative to the previously existing proportions.

For those reasons, we also consider, as a third scenario, a more gas intensive production structure. If the production of the RES would have taken over by a mix of 75% gas, 20% coal and 5% fuel, the reduction in CO<sub>2</sub> emissions would have been 21,9 millions, and the savings in social costs, something between 901 and 1,450 millions of euros if the cost of one Ton of CO<sub>2</sub> is €25 and €50, respectively.

Table 5 shows the savings in environmental costs as a percentage of the received public aids, which amounted to 1,664 millions during that year. The numbers in the table can be understood as the proportion of the public aids that are justified by the reduction in emissions. The rest of the public aid, up to 100%, should be justified by other kind of social benefits, like the ones suggested in Section 1. Again, recall that the cost of CO<sub>2</sub> must be understood as an imputation of the social cost of emissions, and not as the price in the emissions market.

Of course, the savings vary with the technology. Wind, hydro and biomass are close to the average, whereas solar energy shows much lower numbers. Table 6 separates the figures by technology. The numbers may be biased in favor of biomass and biowaste, as they compute as zero emissions, although better estimations should show some.

**Table 5**  
**Comparison between the savings in CO2 emissions**  
**and public aids towards renewable energies.**  
**Agregate, 2007**

		Substitution by gas	Substitution mix 75:20:5	Substitution mix AEE 55:39:6
€5	In millions of €	426.5	548.5	649.6
	<b>As % of aid</b>	<b>25.6</b>	<b>33.0</b>	<b>39.0</b>
€0	In millions of €	853.1	1097.1	1299.2
	<b>As % of aid</b>	<b>51.3</b>	<b>66.0</b>	<b>78.1</b>

Source: Own elaboration<sup>15</sup>

The year 2007 was typical, with no important deviations with respect to the series 2004-2009. The next year, 2008, was atypical due to a drastic increase in solar production, that multiplied by 4.7 the installed capacity, and by 5 the aids received. This situation was corrected in the following year.

**Table 6**  
**Comparison between the savings in CO2 emissions**  
**and public aids towards renewable energies.**  
**By technologies, 2007**

WIND		Substitution by gas	Substitution mix 75:20:5	Substitution mix AEE 55:39:6
€5	In millions of €	289.5	372.7	441.5
	<b>As % of aid</b>	<b>29.1</b>	<b>37.5</b>	<b>44.4</b>
€0	In millions of €	579.0	745.4	883.0
	<b>As % of aid</b>	<b>58.2</b>	<b>74.9</b>	<b>88.7</b>

SOLAR		Substitution by gas	Substitution mix 75:20:5	Substitution mix AEE 55:39:6
€5	In millions of €	4.0	5.5	6.7
	<b>As % of aid</b>	<b>2.1</b>	<b>2.8</b>	<b>3.5</b>
€0	In millions of €	8.0	11.0	13.5
	<b>As % of aid</b>	<b>4.1</b>	<b>5.7</b>	<b>7</b>

<sup>15</sup> See Appendix for details.

HYDRO				
€5	In millions of €	43.9	56.3	66.6
	<b>As % of aid</b>	<b>30.1</b>	<b>38.5</b>	<b>133.1</b>
€0	In millions of €	87.8	112.5	133.1
	<b>As % of aid</b>	<b>60.1</b>	<b>77.1</b>	<b>91.2</b>

BIOMASS AND BIOWASTE				
€5	In millions of €	89.1	114.1	134.8
	<b>As % of aid</b>	<b>27.1</b>	<b>34.7</b>	<b>41.0</b>
€0	In millions of €	178.3	228.1	269.6
	<b>As % of aid</b>	<b>54.2</b>	<b>69.3</b>	<b>81.9</b>

Source: Own elaboration<sup>16</sup>

### 5.1 The change in total surplus and the aids toward wind power.

The equivalent premium to wind power (revenues above market price) amounted 995 millions of euros in the year of 2007. The difference in costs between the wind and gas technologies is about 2.4 c€/kWh and the equivalent premium was calculated as 3.6 c€/kWh. This means that  $3.6 - 2.4 = 1.2$  c€/kWh is an excess over the difference in costs, and it is a part of the public aid that has no effect in switching technologies (2.4 c€/kWh was enough). Thus, out of the 995 millions of euros of the equivalent premium, 66.67% (the proportion  $\frac{2.4}{3.6} \times 100$ ), that is 663.3 millions, are necessary to replace gas with wind, and 33.33%, 221.7 millions, are just a money transfer from consumers to producers.

These numbers change according to the price of CO<sub>2</sub> in the market for emissions. Table 3 showed that, for every €10 of increase in the price of one ton of CO<sub>2</sub>, the cost of the gas technology increased in 0.43 c€/kWh. The difference in costs between wind and gas will decrease accordingly as the price for emissions rights increases. If the price of CO<sub>2</sub> is high enough so that the wind is cheaper, the premium will no longer be necessary to induce a switch in technologies and it will constitute a money transfer in its totality if it is still used. This illustrates the fact that the global cost-benefit analysis must be done comparing the price and social cost of CO<sub>2</sub>. Whenever the premium is necessary to make the wind profitable for the firms, the benefits due to reductions in emissions must be compared with the premium, and the premium should be divided between the part necessary for the technological switch and the money transfer.

The change in total surplus due to public aids towards the wind power in 2007 can be then estimated comparing the 663.3 millions in aids that were necessary to make the wind generation profitable with the savings in social costs. Since during the year 2007 the price of CO<sub>2</sub> was very low, we do not include it in the estimation of this difference. To perform the calculation for other years with higher prices for CO<sub>2</sub>, one should

<sup>16</sup> See Appendix for details.

subtract this cost from the part of the premium that is necessary to switch technologies. For very low prices of CO2 the analysis would not change much. Table 7 displays the amount of the premium that is not a money transfer and is, thus, necessary to switch technologies as a percentage of the saved social cost in the different scenarios.

**Table 7**  
**Percentage of the value of environmental cost reductions**  
**over the net cost of aids to wind generation in 2007 in Spain**

	Substitution by gas	Substitution mix 75:20:5	Substitution mix AEE 55:39:6
Coste social del CO2 a 25 €/Tm	43.9	54.2	67.5
Coste social del CO2 a 50 €/Tm	87.8	108.3	135.0

Source: Own elaboration <sup>17</sup>

## 6. Conclusion

We have shown that a great percentage of total aids towards RES are justified in terms of social savings due to the reduction in CO2 emissions. Whether the whole percentage is justified depends on the economic cost of other benefits of RES use, like reduction in pollution, energy independence and the advantage of being first in the development and use of the new technologies. It is therefore necessary to estimate those other benefits to give a definite answer to the question of whether the aids make economic sense<sup>18</sup>. So far we lack the necessary data. Nevertheless, the analysis presented here is of interests, as it provides a good perspective on the size of the aids vs. the quantified and unquantified benefits.

---

<sup>17</sup> See Appendix for details.

<sup>18</sup> Elsewhere, in Escribano and Ferreira (2010), we include the pollution costs of the different technologies according to the CE report of 2003, and find that the aids account for 30.4% – 113.3% of the aids (compared to 25.6% - 71.8% in Table 5) and that, for wind, the aids account for 51.1% - 185% of the net cost of aids (compared to 43.9% - 135% in Table 7.)

## Appendix

### A.1 Calculations for Table 1

Table A.1 shows the cost estimations from different sources.

**Table A.1**  
**RES costs estimations**

	CNE (including CO2 at €18/Ton)	CNE excluding CO2	El Mundo (private costs)	OMEL Market price according to marginal technology	OMEL excluding CO2	Solino- Prada (private costs in 2000)
Hydro	39	39	45			30-130
Nuclear	44.37	44.37	36			
Coal	71.83	51.83	52			53-129
Gas	68.64	62.24	60	75	66.4	51-81
Wind	-	-	84			50-100
Fuel	-	-	-	110	95.5	75-117

The data in Table 1 are computed after these estimations taking into account the following:

- The costs excluding CO2 are computed using the data in Table 2.
- All data are for the year 2008 except Solino and Prada, that show data for 2000.
- The source in OMEL is used to estimate the cost of Fuel, assuming that the market price when Fuel is the marginal technology reflects the marginal cost of that technology. Using these data, Miera *et al.* (2008) show that when fuel is the marginal technology, the price is 110, while when the gas is marginal the price is 75. The market price for CO2 was €20 that day, which represents an added cost of 14.5 (0.725x20) for fuel and 8.6 (0.43x20) for gas.
- See that the assumption that the cost of gas is the market price when gas is the marginal technology is above the estimation by CNE (66.4 vs. 62.24) and by El Mundo (66.4 vs. 60). The difference, around between 4.16 and 6.4, can be thought as the mark up.
- Solino and Prada is presented as a double check for the data on Wind and Fuel.
- For Hydro, Nuclear, Coal, and Gas, Table 1 is computed as the rounded average of CNE excluding CO2 and El Mundo. For Wind it uses the data in El Mundo, and for Fuel it uses the data in OMEL excluding CO2, and deducing a mark up of 5 (using the mark up for gas as a proxy).

### A.2 Calculations for Table 2

Columns 2 and 3 in Table 2 are taken directly from the CE 2003 report. Column 1 is an estimation of costs excluding CO2 using the following equations:

$$A_i + 18B_i = C_i,$$

$$A_i + 46B_i = D_i.$$



Where, for technology  $i$ ,  $C_i$  is the marginal environmental costs of all impacts with CO2 at €18 a ton., and  $D_i$  is the marginal environmental costs of all impacts with CO2 at €46. Then,  $A_i$  represents the marginal environmental costs excluding CO2 and  $B_i$  represents the cost per kWh of CO2 at €1 a ton.  $C_i$  and  $D_i$  are the data given by the CE report (columns 2 and 3 in Table 2).  $A_i$  and  $B_i$  are deduced from the equations, which gives

$$A_{coal} = 3.07, B_{coal} = 0.107$$

$$A_{fuel} = 2.07, B_{fuel} = 0.107$$

$$A_{gas} = 0.36, B_{gas} = 0.036.$$

### A.3 Calculations for Table 3

Table A.2 shows the estimations for CO2 emissions from different sources.

**Table A.2**  
**RES emissions**

Tn. CO2/ mWh	REE	CE 2003	WEC	SGE
Hydro	0	0	0.004	
Nuclear	0	0	0.006	0
Coal	0.95	1.07	0.8-1.05	0.95-1.004
Gas	0.37	0.36	0.43	0.425
Wind	0	0	0.003-0.022	0
Fuel	0.70	1.07	-	0.754
other RES	0.25	-	-	-
Photovoltaic			0.06-0.15	0

The data in WEC and SGE compute the emissions in the complete life cycle of the plant. We use the average of these two numbers (when positive) for the data in Column 1 in Table 3. We use the data in WEC for the rest.

### A.4 Calculations for tables 5 and 6

Tables A.3, A.4 and A.5 are constructed as follows. Production is taken from Table 4, which uses data from the CNE annual report. Column 2 is computed using the data in Table 3. Column 3 is Column 1 multiplied by Column 2 and using the appropriate units. Columns 4 and 5 are the result of multiplying Columns 2 and 3 by 25 and 50, respectively.

**Table A.3**  
**Effects of substituting RES with gas in 2007**

Substitution with gas	Production GWh	Difference in CO2 emissions Grams per kWh	Reduction in CO2 emissions Millions of tons	Savings in CO2 costs at €25 Millions of €	Savings in CO2 costs at €50 Millions of €
Wind	27,474	421,5	11.58	289.5	579.0
Solar	495	325	0.16	4.0	8.0
Hydro	4,120	426	1.76	43.9	87.8
Biomass	8,292	430	3.56	89.1	178.3
<b>TOTAL</b>	<b>40,381</b>		<b>17.06</b>	<b>426.5</b>	<b>853.1</b>

**Table A.4**  
**Effects of substituting RES with coal in 2007**

Substitution with coal	Production GWh	Difference in CO2 emissions Grams per kWh	Reduction in CO2 emissions Millions of tons	Savings in CO2 costs at 25€ Millions of €	Savings in CO2 costs at 50€ Millions of €
Wind	27.474	941.5	25.9	646.7	1293.3
Solar	495	845	0,4	10.5	20.9
Hydro	4.120	946	3.9	97.4	194.9
Biomass	8.292	950	7.9	296.9	393.9
<b>TOTAL</b>	<b>40,381</b>		<b>38,1</b>	<b>951.5</b>	<b>1.903.0</b>

**Table A.5**  
**Effects of substituting RES with fuel in 2007**

Substitution with fuel	Production GWh	Difference in CO2 emissions Grams per kWh	Reduction in CO2 emissions Millions of tons	Savings in CO2 costs at €25 Millions of €	Savings in CO2 costs at €50 Millions of €
Wind	27.474	764.5	21.0	525.1	1050.2
Solar	495	649	0.3	8.0	16.1
Hydro	4.120	750	3.1	77.3	154.5
Biomass	8.292	754	6.3	156.3	312,6
<b>TOTAL</b>	<b>40,381</b>		<b>30.7</b>	<b>766.7</b>	<b>1533.3</b>

Table A.6 shows the savings in CO2 emissions' costs for the different RES. The first two rows in each technology show the absolute numbers. For Columns 1, 2 and 3, the numbers are taken from Columns 3 and 4 in Table A.5. Columns 4 and 5 are calculated as the weighted average of Columns 1, 2, and 3 according to the percentages in the mix.

Finally, the numbers in the last two rows in each technology show the same quantities as the numbers in the first two rows, but now as a percentage of the public aids given to that technology.

Table A.7 shows the aggregate of Tables A.3, A.4 and A.5.

**Table A.6**  
**Savings in CO2 emissions costs for each RES**

<b>Savings with Wind</b>		Gas	Coal	Fuel	Mix 70:20:5	Mix 55:39:6
CO2 at 25 €		289.5	646.7	525.1	372.7	441.5
CO2 at 50 €		579.0	1,293.3	1050.2	745.4	883.0
As % of aids (995 millions €)	at 25 €	29.1	65.0	52.8	37.5	44.4
	at 50 €	58.2	130.0	105.6	74.9	88.7

<b>Savings with Solar</b>		Gas	Coal	Fuel	Mix 70:20:5	Mix 55:39:6
CO2 at 25 €		4.0	10.5	8.0	5.5	6.7
CO2 at 50 €		8.0	20.9	16.1	11.0	13.5
As % of aids (194 millions €)	at 25 €	2.1	5.4	4.1	2.8	3.5
	at 50 €	4.1	10.8	8.3	5.7	7

<b>Savings with Hydro</b>		Gas	Coal	Fuel	Mix 70:20:5	Mix 55:39:6
CO2 at 25 €		43.9	97.4	77.3	56.3	66.6
CO2 at 50 €		87.8	194.9	154.5	112.5	133.1
As % of aids (146 millions €)	at 25 €	30.1	66.7	52.9	38.5	45.6
	at 50 €	60.1	133.5	105.8	77.1	91.2

<b>Savings with Biomass</b>		Gas	Coal	Fuel	Mix 70:20:5	Mix 55:39:6
CO2 at 25 €		89.1	196.9	156.3	114.1	134.8
CO2 at 50 €		178.3	393.9	312.6	228.1	269.6
As % of aids (329 millions €)	at 25 €	27.1	59.9	47.5	34.7	41.0
	at 50 €	54.2	119.7	95.0	69.3	81.9

**Table A.7**  
**Aggregate savings in CO2 emissions costs**

<b>Total Savings</b>		Gas	Coal	Fuel	Mix 70:20:5	Mix 55:39:6
CO2 at 25 €		426.5	951.5	766.7	548.5	649.6
CO2 at 50 €		853.1	1903.0	1,533.4	1097.1	1299.2
As % of aids (1.664 millions €)	at 25 €	25.6	57.2	46.1	33.0	39.0
	at 50 €	51.3	114.4	92.1	69.9	78.1

## A.5 Calculations for Table 7

The cost of substituting the power generated with wind with an alternative is calculated as follows:

With gas: 6

With mix 70:20:5:  $0.75 \times 6 + 0.2 \times 5.2 + 0.05 \times 9.6 = 6.02$

With mix 55:39:6:  $0.555 \times 6 + 0.388 \times 5.2 + 0.057 \times 9.6 = 5.8948$ .

The difference between the premium (3.62 as seen in Table 4) and the cost is, then, 2.38, 2.4, and 2.2748 respectively. These quantities represent a percentage of 66.3, 65.7 and 69.2, respectively. Finally, this gives 659.7, 654.2, and 688.6 as the part of aids that is necessary to change the mix for wind.

Table 7 shows the savings in emissions costs as seen in Table 6 as a proportion of these quantities.

## References

Asociación Empresarial Eólica (AEE), 2008a. Macroeconomic study of the impact of the wind sector in Spain (in Spanish). Available at <<http://www.aeeolica.es>>

Asociación Empresarial Eólica (AEE), 2008b. Eólica 2008 (in Spanish). Available at <<http://www.aeeolica.es>>.

Allianz Knowledge, 2010. Do Carbon Markets Really Help the Climate? Available at <<http://knowledge.allianz.com>>.

Carbonpositive, October 2010. EU carbon prices rely heavily on targets, CER rules. EUA markets reports. Available at <<http://www.carbonpositive.net>>.

Comisión Nacional de la Energía (CNE). May 2008a. “Informe complementario a la propuesta de revisión de tarifa” (Complementary report on the proposal for tariff revision).

Comisión Nacional de la Energía (CNE), 2008b. Basic information on the energy sectors, 2008 (in Spanish). Available at <<http://www.cne.es>>.

El Mundo newspaper, January 20 2008. Markets section, Madrid.

Escribano, A., and JL. Ferreira, “The rationality of public incentives towards renewable electricity,” (in Spanish), mimeo, Universidad Carlos III de Madrid, 2010.

European Commission, 2003. External Costs. Research Results on Socio-Environmental Damages Due to Electricity and Transport, Office for Official Publications of the European Communities.

European Commission, 2006. EmployRES: The impact of renewable energy policy on economic growth and employment in the European Union. Final report, Contract no.: TREN/D1/474/2006.

Instituto para la Diversificación y Ahorro de Energía (IDAE), 1999. Impactos Ambientales de la Producción Eléctrica: Análisis de Ciclo de Vida de ocho tecnologías de generación eléctrica (Environmental Impact of Electricity Production: Análisis of the Life Cycle of Eight Generation Technologies), Madrid.. Available at <<http://www.appa.es>>.

Jensen, S., Skytte, K., 2003. Simultaneous attainment of energy goals by means of green certificates and emission permits. Energy Policy 31, 63–71.

Morthorst, P.E., 2001. Interactions of a tradable green certificate market with a tradable permits market. Energy Policy 29, 345–353.

Morthorst, P.E., 2003. National environmental targets and international emission reduction instruments. Energy Policy 31, 73–83.

Point Carbon, 2008. Carbon 2008 - Post-2012 is now, Røine, K., E. Tvinnereim and H. Hasselknippe (eds.)

Red Eléctrica de España (REE), June 2009, Red Eléctrica publica en su web las emisiones de CO2 producidas en el sistema eléctrico en tiempo real (REE publishes in its web site the CO2 emissions produced by the electric system in real time), press note, Gabinete de Prensa. Available at <<http://www.ree.es>>.

Sáenz de Miera, G., P. del Río and I. Vizcaíno, “Analysing the impact of renewable electricity support schemes on power prices: The case of wind electricity in Spain”, *Energy Policy* 36, 3345-3359, 2008.

Secretaría General de Energía (SGE), February, 2009. Department of Planning and Studies, Report.

Soliño, M. and Prada, A., November 2005. Costes sociales de la electricidad verde en intervención pública: aplicación al caso de la biomasa forestal (Social costs of green electricity in public intervention: an application to the case of forest biomass), VII Jornadas de Política Económica.

Rathmann, M., 2007. Do support systems for RES-E reduce EU-ETS-driven electricity prices? *Energy Policy* 35 (1), 342–349.

World Energy Council, 2007. Performance of Generating Plant: Managing the Changes.